

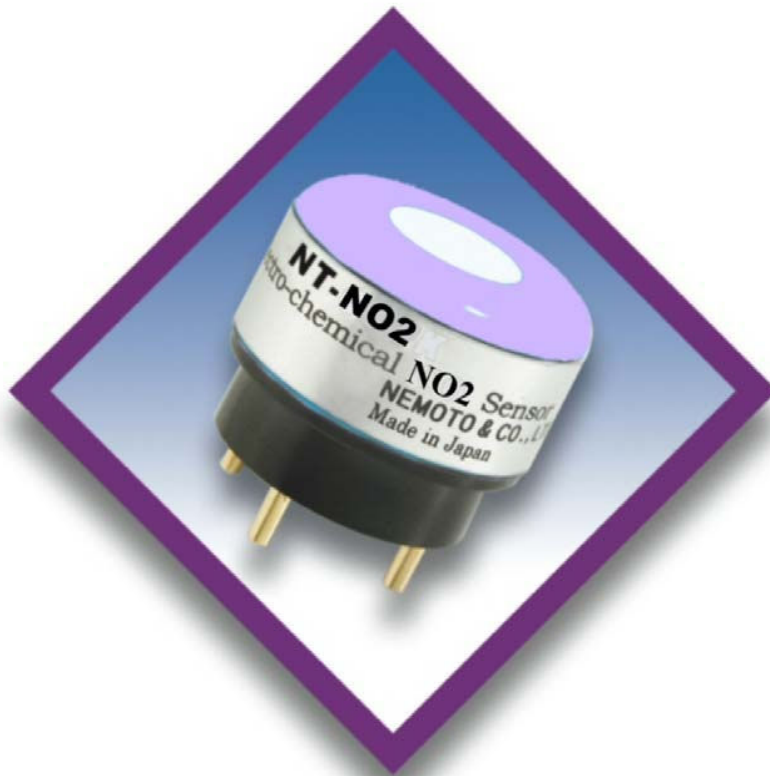

nemototech

USER MANUAL & CHARACTERISATION DATA

NT-NO2 Electrochemical Nitrogen Dioxide Gas Sensor



NEMOTOTECH S.r.l. – 20010 Cornaredo (MI) ITALY Via Legnano, 2 – Tel.+39.02.93544190 – Fax +39 .02. 93540347
C.F. e P. IVA (VAT) 03231490966 – CAPITAL . 36.000 EU – Website: www.nemototech.it – E-mail: info@nemototech.it



INTRODUCTION

Nemoto & Co. Ltd was established in 1941 and continues to develop unique technologies for the Safety, Security and Health markets. Using our unique experience of fine chemical preparation and printing, we were able to enter the gas sensor market in 1979 with a range of high-quality hot-wire type sensors (pellistors). Nemoto is now one of the World's leading manufacturers of chemical sensors and has so far delivered over 30-million devices to the market.

As a result of three-years' development at our Tokyo R&D centre, we released our first electrochemical sensor, for the monitoring of toxic gases, in 2000.

The NT-NO₂ Gas Sensor is a new 3-Electrode Electrochemical cell designed for the detection and measurement of nitrogen dioxide (NO₂) in the range 0.20 ppm. By adhering to industry standards for size and connection orientation the NT-NO₂ can be retrofitted easily to existing product designs.

By using our experience of design for manufacture and our high volume production facilities, we have successfully reduced the cost of the NT-NO₂ compared with other similar sensors whilst being able to maintain the highest performance quality.

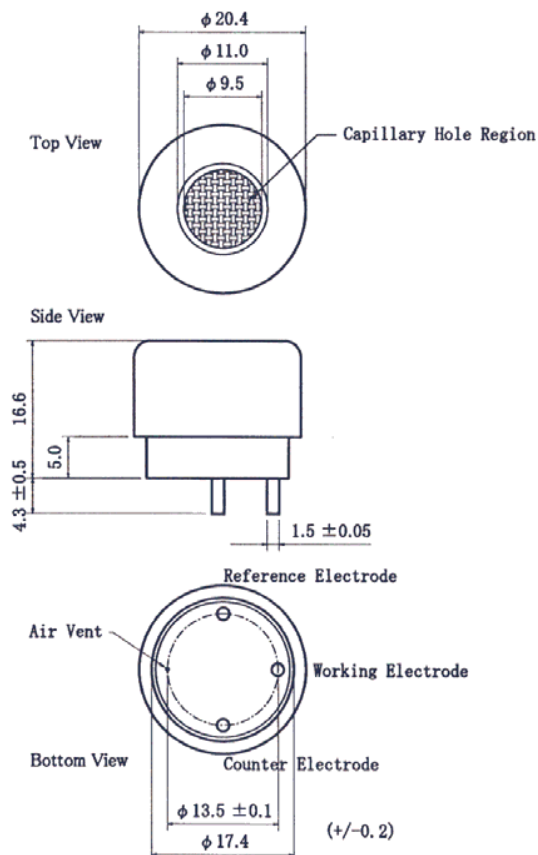

This characterisation document does not constitute a specification but is intended as a guide, informing the instrument designer of the performance characteristics of the sensor which were observed by Nemototech's Engineers.

It should be read in conjunction with Technical Information Sheet ds-n-nt-no2.doc, which includes the full technical specification for the NT-NO₂ Gas Sensor.

PRINCIPLES OF OPERATION

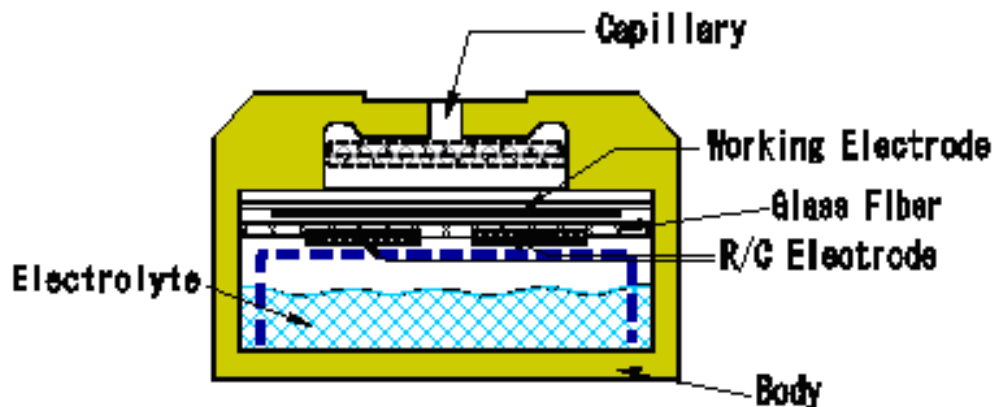

The NT-NO₂ consists of 3 porous metal electrodes separated by an acidic aqueous electrolyte, housed within a plastic (PPO) enclosure. Gas enters the cell via a gas phase diffusion barrier (capillary) and a chemical filter that removes unwanted gases which might interfere with the sensors performance or give a false signal. An electrolyte reservoir ensures an excess of electrolyte is available at all times, and the sensor is vented to ensure that the internal and external pressure of the sensor is in equilibrium.

In operation, gas enters the cell via the capillary and filter, and comes into contact with the 'working' electrode. Any nitrogen dioxide present undergoes a chemical reaction known as "reduction". The reduction reaction involves the consumption of electrons (which are supplied by the electrode material) and hydrogen ions (which are supplied by the electrolyte)

The reaction at the working electrode is balanced by a reciprocal (oxidation) reaction at the 'counter' electrode, using Oxygen from the surrounding atmosphere. This reaction generates electrons (which are conducted away by the electrode material) and hydrogen ions (which diffuse into the electrolyte).

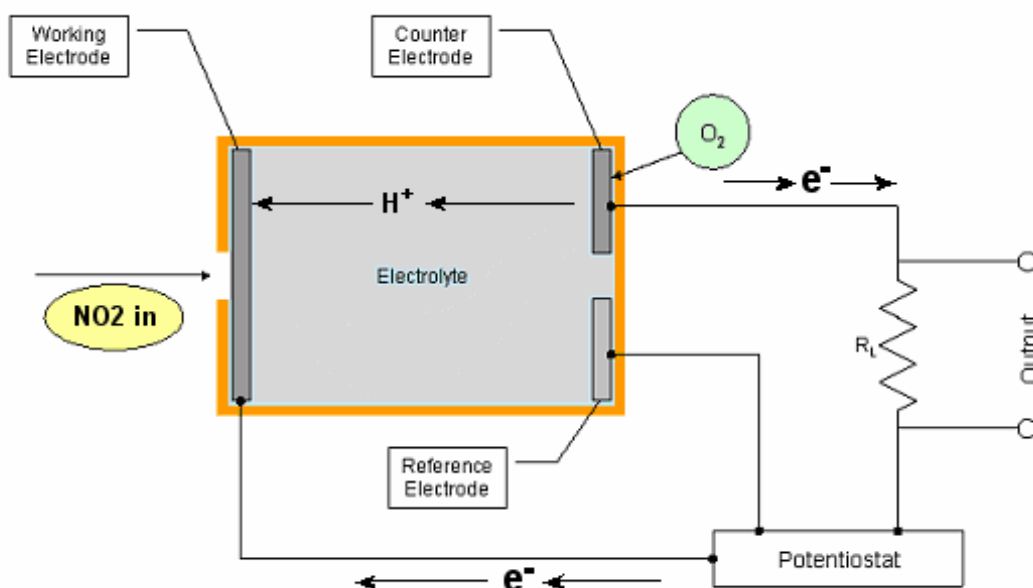



So we have one electrode consuming electrons. Whilst the other generates electrons. The two electrodes are connected to the external circuit via metal strips, and the flow of electrons between the two electrodes is measured as a micro-amp level current signal which is directly proportional to the ppm level of Nitrogen dioxide present.

The 'reference' electrode maintains the healthy operation of the cell. It is surrounded by electrolyte, sees no gas and no current is allowed to be drawn from it. Its electrochemical potential hence always remains constant at a level known as the "rest air potential" and this is used to regulate the potential of the working electrode, regardless of the current it is generating during operation. The use of a reference electrode in this way (i.e. three-electrode operation) helps to extend the working range of the sensor, improves linearity and results in a number of performance benefits compared with similar sensors working with 2-electrodes only.

FEATURES

Electrochemical gas sensors have the following superiority to conventional semiconductor type and hot-wire type gas sensors.

- **Linear output in proportion to gas concentration**
- **High reproducibility**
- **Highly gas specific**
- **Unaffected by humidity**
- **Stable output for long periods**
- **Low power consumption because no heater is used (can be battery operated)**
- **Small and lightweight (can be used in portable devices)**
- **No mechanical structure so highly resistant to shocks and vibrations.**

NT-NO₂ has been developed from our accumulation of technologies in production of hot-wire type gas sensors, long research experience into catalysts, fine printing, and assembling of sensors. The NT-NO₂ is smaller and less expensive than similar designs, but has high sensitivity, long life, and leak-free performance even under severe operating conditions.

Air vent

The electrolyte used for chemical sensors is very hygroscopic, i.e. it has affinity for water, and its volume varies depending on ambient temperature and humidity. This variation causes pressure inside the sensor to rise and fall. In the worst case the electrolyte may leak out of the sensor and damage the circuitry around it.

To prevent this, the NT-NO₂ utilizes an air vent capability. This maintains equilibrium between internal and external pressures and allows the sensor to be used in any orientation and under high temperature and humidity conditions.



PERFORMANCE DATA

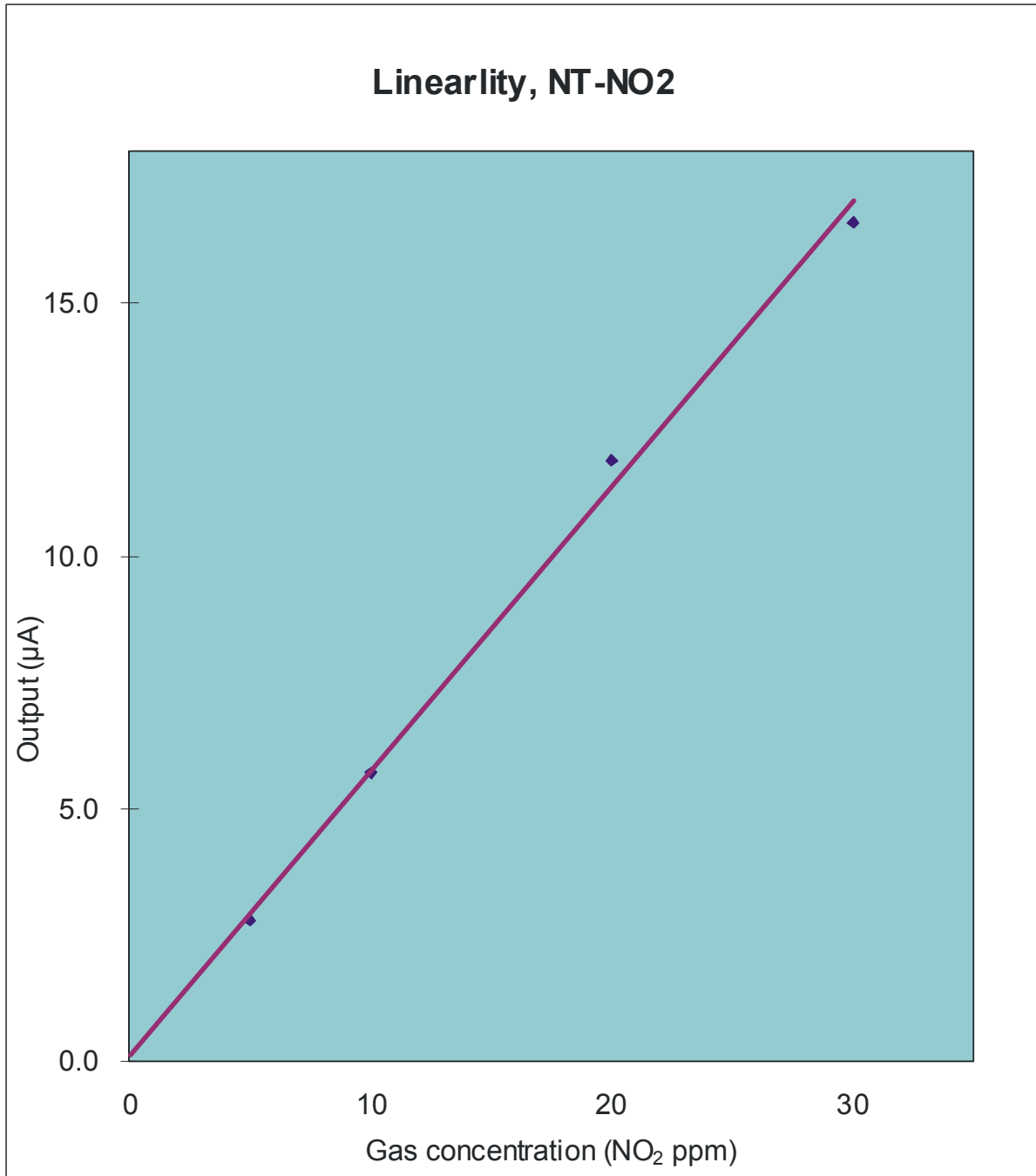

The above plot represents the mean results from tests conducted on 3 sensors

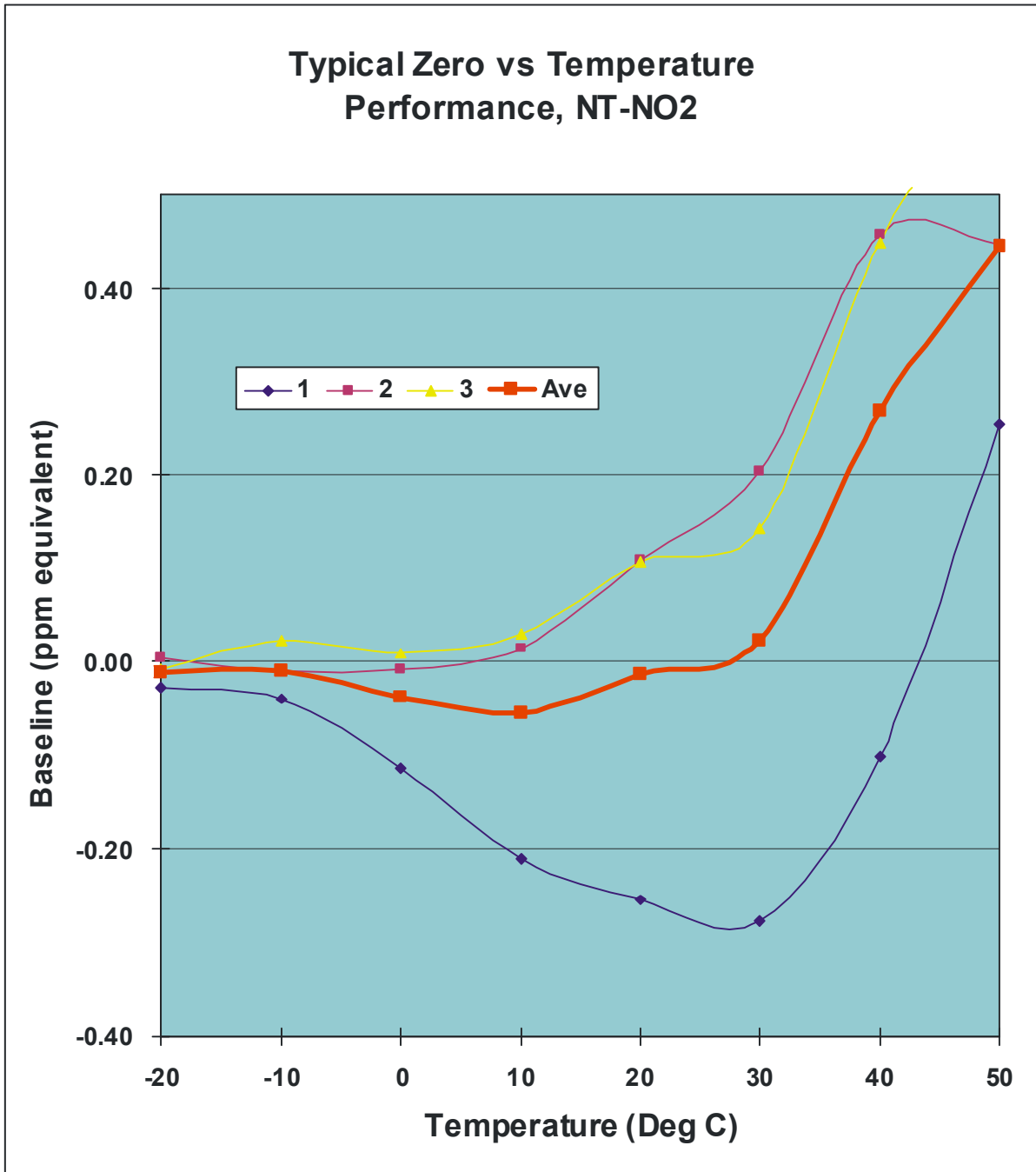

The Red line represents the mean results from tests conducted on 3 sensors. The other three lines represent the results for the individual sensors.

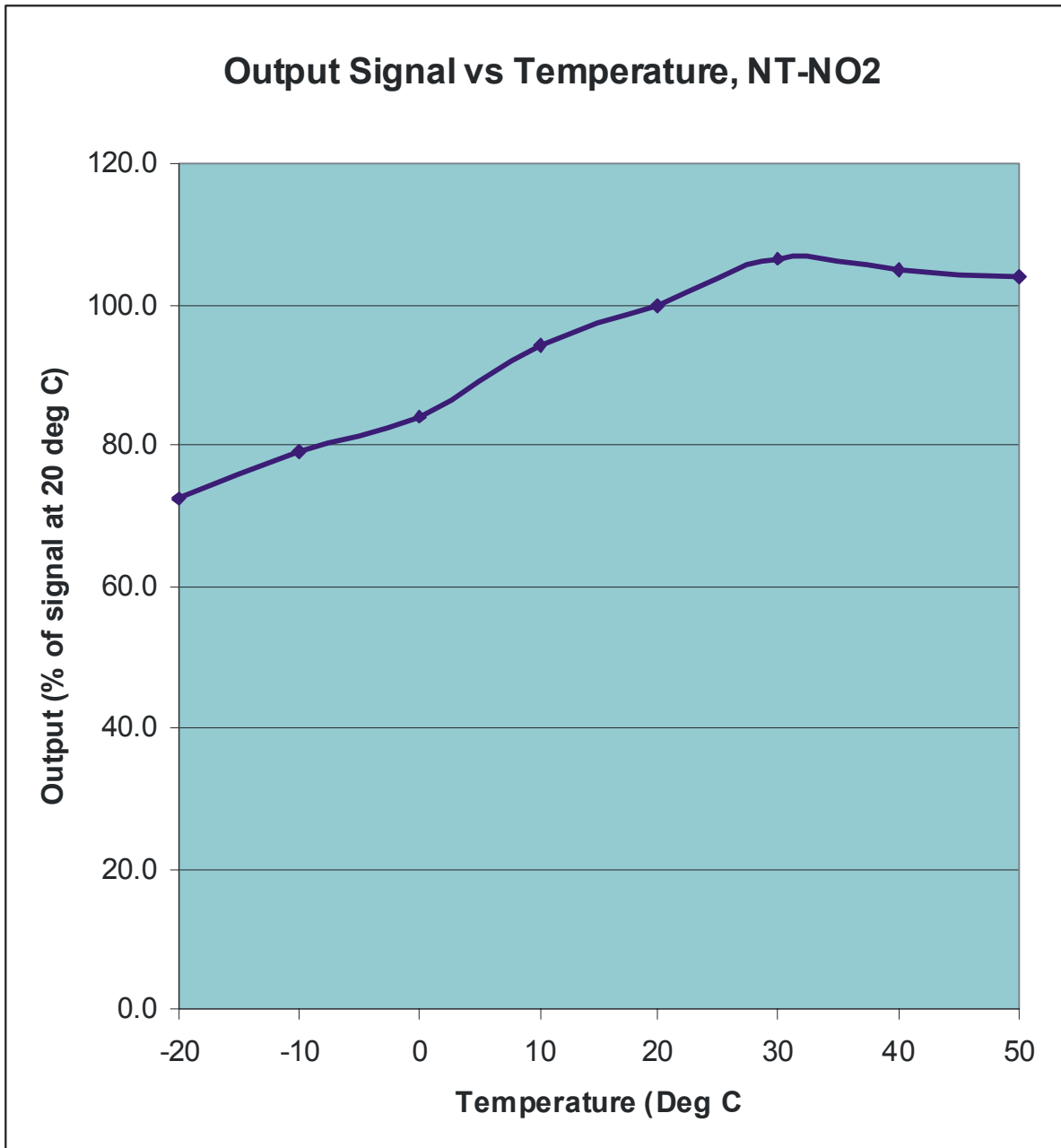

The above plot represents the mean results from tests conducted on 3 sensors. The individual results were considered to be too close to the mean to warrant including them on the plot.

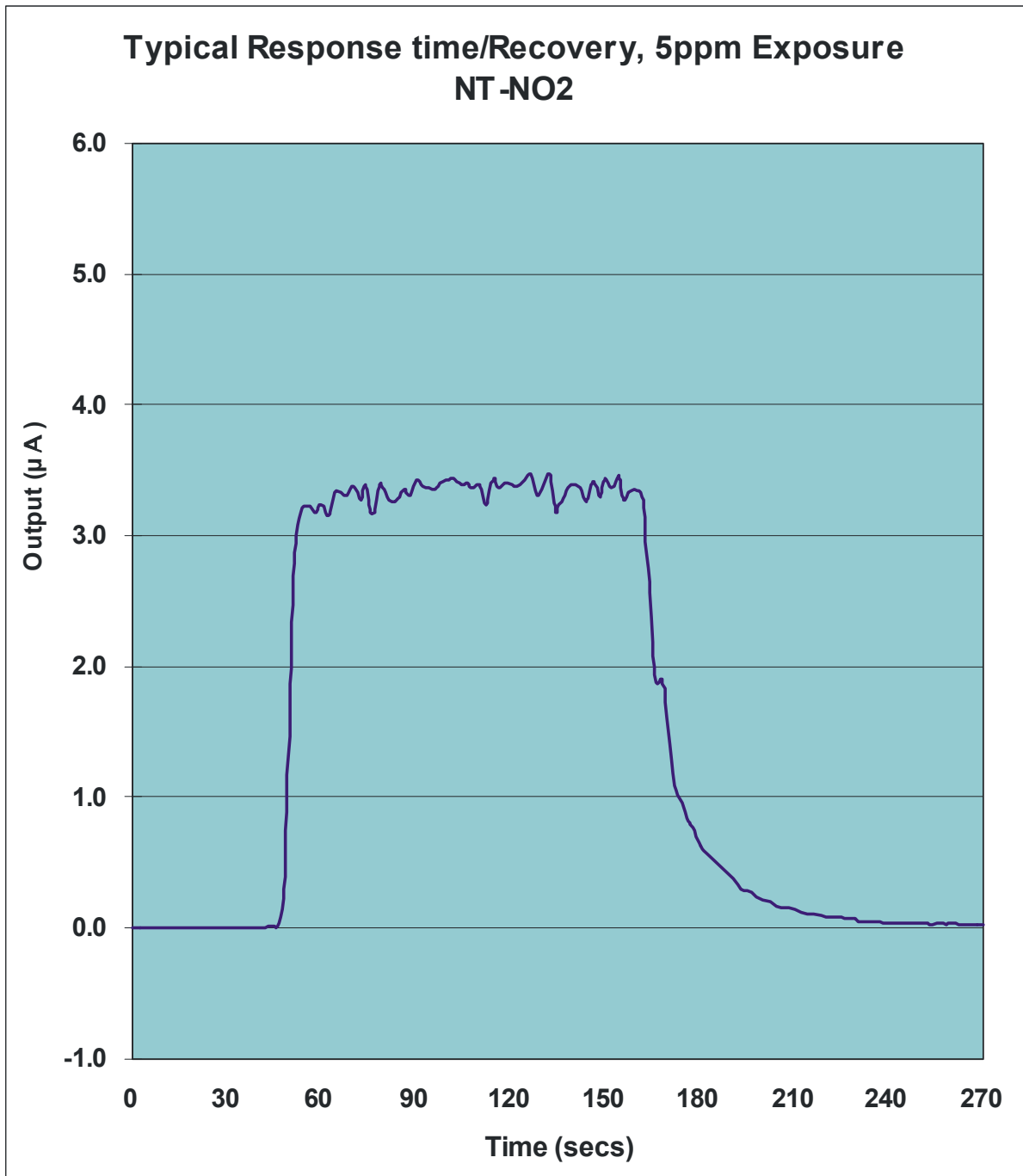

3)



Cross Sensitivities:

The following table gives cross sensitivity information for a variety of commonly encountered gases.

| Gas | Test Concentration (ppm) | Typical Nitrogen Dioxide Concentration (ppm equivalent) | % Cross Sensitivity |
|------------------|--------------------------|---|---------------------|
| Nitrogen Dioxide | 100 | 100 | 100 |
| Nitric Oxide | 50 | 0 | 0 |
| Carbon Dioxide | 5000 | 0 | 0 |
| Carbon Monoxide | 400 | 0 | 0 |
| Sulphur Dioxide | 30 | -0.6 | <-2 |
| Hydrogen Sulfide | 20 | <-25 | <-125 |
| Hydrogen | 1000 | 0 | 0 |
| Ethyl Acetate | 100 | <0.5 | <0.5 |
| Ethanol | 100 | 0 | 0 |
| Chlorine | 1 | 1 | 100 |
| Ethylene | 500 | 0 | 0 |
| Toluene | 50 | <1.5 | <3 |
| Ammonia | 100 | 0 | 0 |

DEFINITIONS

Gas sensitivity / Output signals

Using the NT-NO₂, 600 ± 150nA is generated at 1ppm of NO₂ gas. For instance, the generated current value will be about 6µA at 10 ppm of NO₂ gas (10 ppm x 600 nA). This generated current is generally recorded as a voltage produced by a Current – Voltage converting circuit. In our recommended circuit, as the conversion is done through a resistor of 10 kΩ.

NOTE: The polarity of the signal for an NT-NO₂ sensor is in the opposite direction to that of most other gas sensors of this type, such as CO or H₂S sensors.

Response time (t₉₀)

This is the time taken to reach to 90% of the maximum output value in clean air.

Repeatability

This is the maximum variation of output signals when tests are repeated under the same measuring conditions (temperature, humidity, gas concentration etc.). The repeatability of NT-NO₂ is ± 2%, and this means that all of the test results would fall in the range of 98% ~ 102%.

Temperature dependence

All electrochemical sensors are affected by changes in the ambient temperature and the output increases as the ambient temperature rises. This is caused by the rate of oxidation reaction on the



surface of the catalyst, the dispersibility of the gas in the capillary, and the thermal effects on the mobility of ions in the electrolyte. This temperature dependency can be compensated relatively easily by using a NTC thermistor.

RECOMMENDED CIRCUIT SUGGESTION

The following circuit includes for temperature correction using an NTC thermistor (TH). Amplifiers are precision low input offset types, eg OP90 or similar.

We are aware that many instrument designers have greater expertise in circuit design than we do, and so the circuit is for general guidance only and is not intended to be prescriptive.

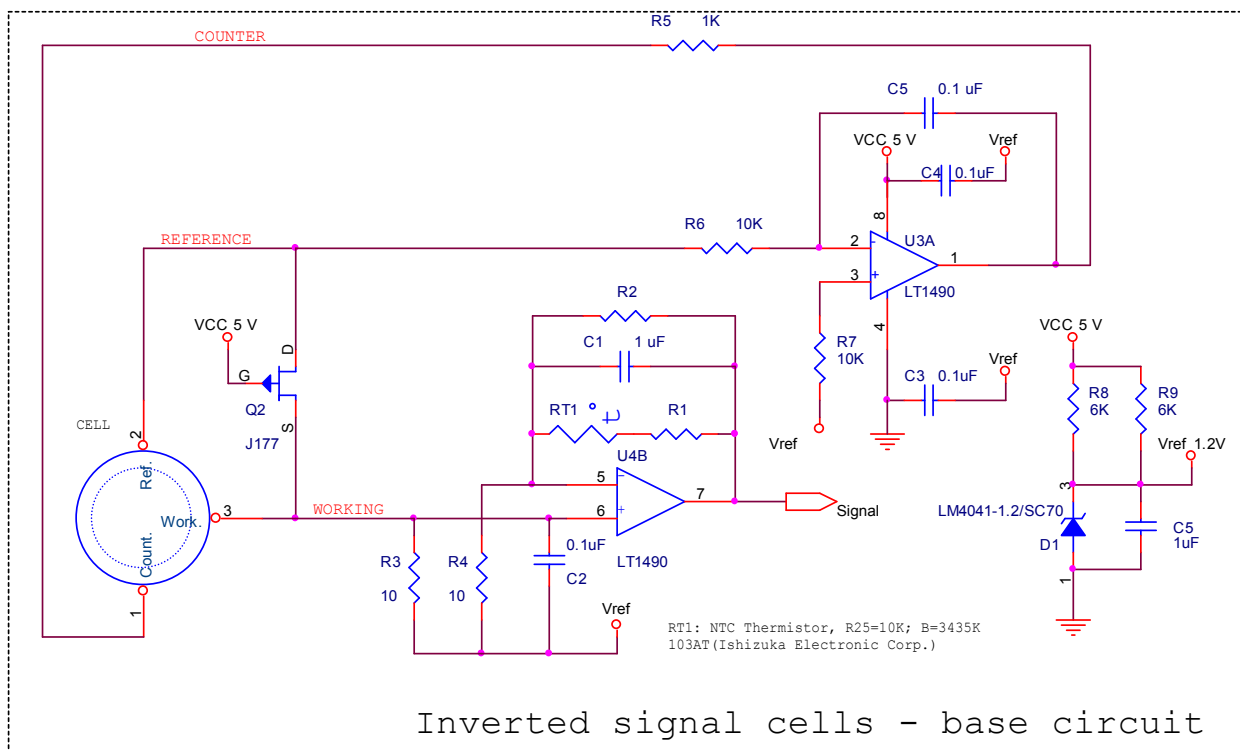



NOTES

1) Long-term drift of gas sensitivity

All electrochemical gas sensors lose sensitivity over time due to small changes on the surface of the working electrode, reducing its oxidation capability. To reduce this, the NT-NO₂ uses a newly developed electrode resulting in a specification for long term output drift of less than 2%/month. We recommend that this potential deterioration should be taken into account when designing and specifying instruments.

2) Storage of sensors

Electrochemical sensors should be stored in a clean air under room temperature, preferably 0 °C ~20°C and in non-condensing RH conditions. The maximum storage period would be 6 months after delivery. For sensors stored for more than 6 months, the performance guaranteed period will be shortened by the excess storage period. Unlike semiconductor type or hot-wire type gas sensors, the gas sensitivity of electrochemical gas sensors will change as time passes regardless of whether sensor has been used or not.

3) Mounting sensors

Electrode pins must be connected correctly to ensure operation.

A thermistor for temperature compensation must be located near the sensor and away from heat sources such as transformer.

NT-NO₂ can be mounted in any orientation.

NT-NO₂ pins cannot be soldered as excess heating may cause the deformation of the housing and eventually leakage of electrolyte.

4) Calibration and gas testing

Calibration of detectors or densitometers should be done after the output value has been stabilized in clean air.

Evaluation of gas sensitivity should be made in clean, humidified, air. When a test gas is blown directly to the gas intake area, higher gas sensitivity may be observed. It is therefore best to test and calibrate gas detection instruments and sensors in diffusion mode. This can be achieved by using a suitable test housing where a low flow rate is used (<1l/min) and where the air is agitated to ensure equal gas diffusion throughout.



5) Other

Unless otherwise advised by Nemoto, voltage should not be supplied directly to the electrode pins.

Do not bend the pins.

Take care not to subject the sensor to undue mechanical loads or stress by, for example, the overtightening of gasket seals etc.

Take care not to block the gas intake area as it may prevent gas entering the sensor.

Never put foreign material in the gas intake area as it may cause the electrolyte leakage

Do not expose the sensor to excess vibration or shock.

If the sensor housing is damaged, do not use the sensor.

After the sensor is exposed to high concentration gas for long periods, the output signal may require time to recover to normal operation.

Do not blow organic solvents, paints, chemical agents, oils, or high concentration gases directly onto sensors.

Do not disassemble the sensor as this may cause electrolyte leakage.