



nemototech

TECHNICAL INFORMATION SHEET: NEMOTO NP-18S Single Header Pellistor Gas Sensor



General Description

The Nemoto NP-18S is a catalytic (pellistor) type flammable gas sensor supplied as a matched pair of pellistor elements mounted on a single header and protected by a metal mesh enclosure and can.

The sensor detects and measures the presence of flammable gases and vapours in air, in the range 0-100% of the Lower Explosive Limit (LEL) of the gas or vapour being measured. Designed as a lower cost alternative to the twin-header NP-18 device, the NP-18S may be used as the sensing platform in fixed flammable gas detection systems.

The NP-18S exhibits excellent long term zero and sensitivity stability and a high level of resistance to catalytic poisons. The highly automated manufacturing procedure employed by Nemoto results in a repeatable reliable sensor which, unlike similar devices, requires no trimming resistor to enable the detector to be matched with a compensator.

Nemoto has a policy of continuous development and improvement of its products. As such the specification for the device outlined in the data sheet may be changed without notice

Specifications:

Recommended Voltage:	2.6V +/- 0.1V
Current Drawn:	170 +/- 20mA
Zero Offset:	0mV +/- 30mV
Minimum Sensitivity:	60-90mV/% CH ₄ /Air
Range:	0-100% LEL
Accuracy:	+/- 1%LEL(CH ₄)
Maximum Long Term Drift:	
Span:	< +/- 5% LEL/3 Months
Zero:	< +/- 1/2 mV/Month
Response Time:	T ₅₀ : 3 sec T ₉₀ : 8 sec

Recommended Circuit:

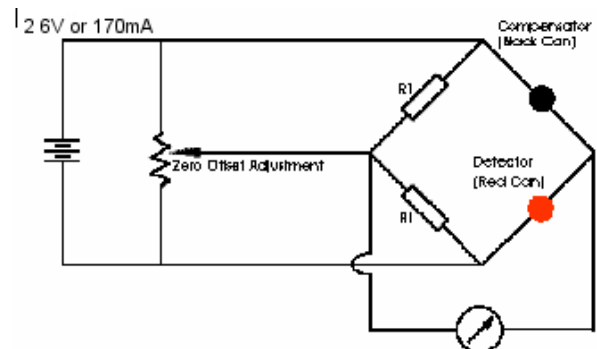

Note: The value R1 is arbitrary, since the function of R1 is to balance the bridge. 1K Ω is suggested.

Temperature Range:	-20°C to +70°C
Temperature Drift:	(-20°C to +70°C)
Zero:	< +/- 2%LEL
Humidity:	0-100%RH, non-condensing
Humidity Response:	+/- 2%LEL
Linearity:	Effectively Linear to 60%LEL

Test data on drift, poisoning, temperature performance, linearity will be available on the Characterisation Document.

ds-np18s.doc, issue 3, May 2008

Sensor Structure, Materials of Construction and Dimensions:

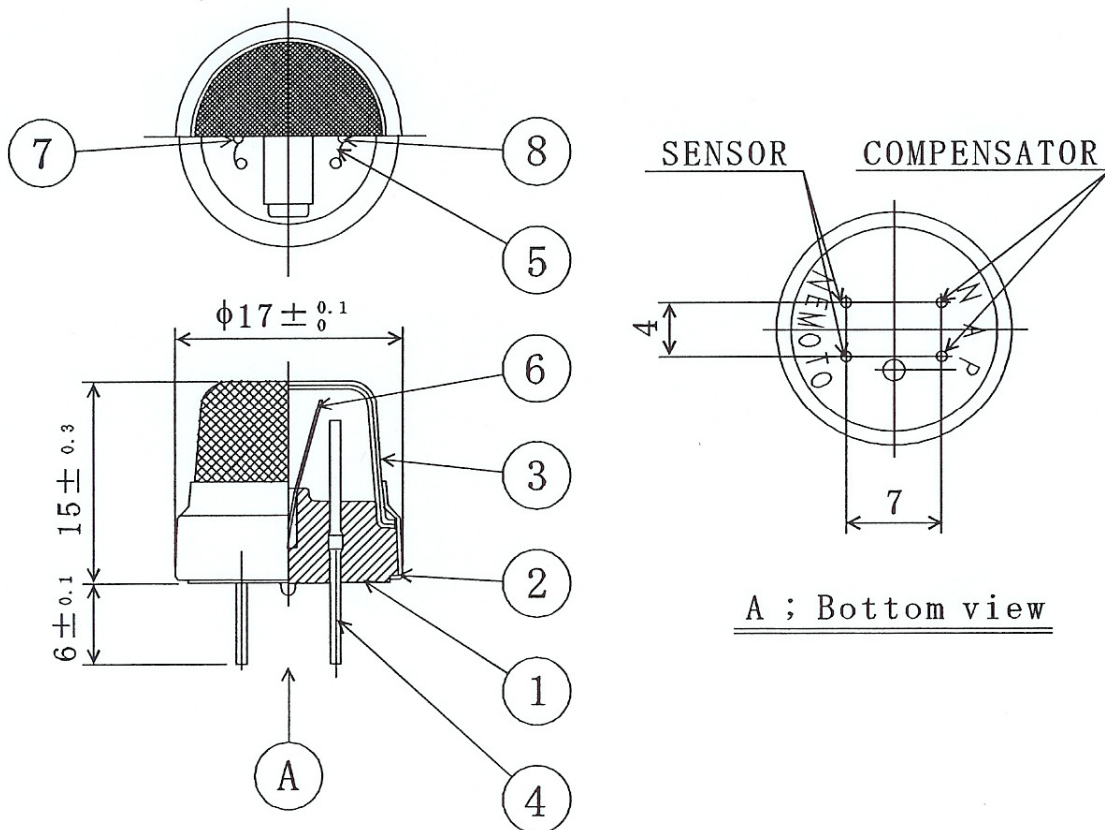

- 1) Mount Base, PM-EE Polymer
- 3) Mesh Enclosure (SS316)
- 5) Filament Coil (Pure Platinum)
- 7) Detecting Element

- 2) Metal skirt (C2680, Nickel plated)
- 4) Pin (Pure Nickel)
- 6) Partition (SS304 CSP)
- 8) Compensator Element