



nemototech

CHARACTERISATION DATA

NP-18S CATALYTIC PELLISTOR GAS SENSOR



NEMOTOTECH S.r.l. – 20010 Cornaredo (MI) ITALY Via Legnano, 2 – Tel.+39.02.93544190 – Fax +39 .02. 93540347
C.F. e P. IVA (VAT) 03231490966 – CAPITAL . 36.000 EU – Website: www.nemototech.it – E-mail: info@nemototech.it

Introduction

The Nemoto NP-18S is a catalytic (pellistor) type flammable gas sensor supplied as a matched pair of elements mounted on a single header and protected by a metal can and mesh. Designed to give Industrial standard performance at low cost, the sensor detects and measures the presence of flammable gases and vapours in air, in the range 0-100% of the Lower Explosive Limit (LEL) of the gas or vapour being measured. Designed as a sensing platform for use in fixed flammable gas detection systems, the NP-30S exhibits excellent long term zero and sensitivity stability. The device is compatible with a wide range of commercially available Gas Detection Systems and remote flammable gas detection heads.

The highly automated manufacturing procedure employed by Nemoto results in a repeatable reliable sensor which, unlike similar devices, requires no trimming resistor to enable the detector to be matched with a compensator.

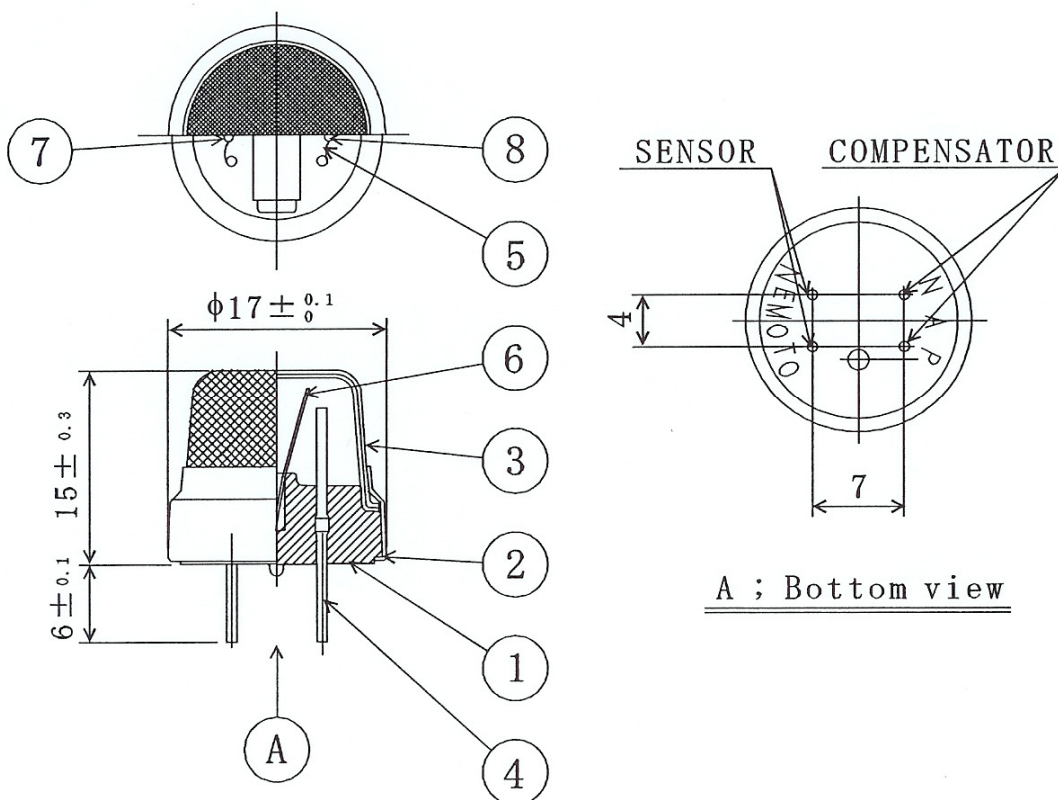

- 1) Mount Base, PM-EE Polymer
- 3) Mesh Enclosure (SS316)
- 5) Filament Coil (Pure Platinum)
- 7) Detecting Element

- 2) Metal skirt (C2680, Nickel plated)
- 4) Pin (Pure Nickel)
- 6) Partition (SS304 CSP)
- 8) Compensator Element

This characterisation document does not constitute a specification but is intended as a guide, informing the instrument designer of the performance characteristics of the sensor which were observed by Nemototch's Engineers.

It should be read in conjunction with Technical Information Sheet ds-np18 s which include the full technical specifications for the NP-18S Pellistor Gas Sensor.

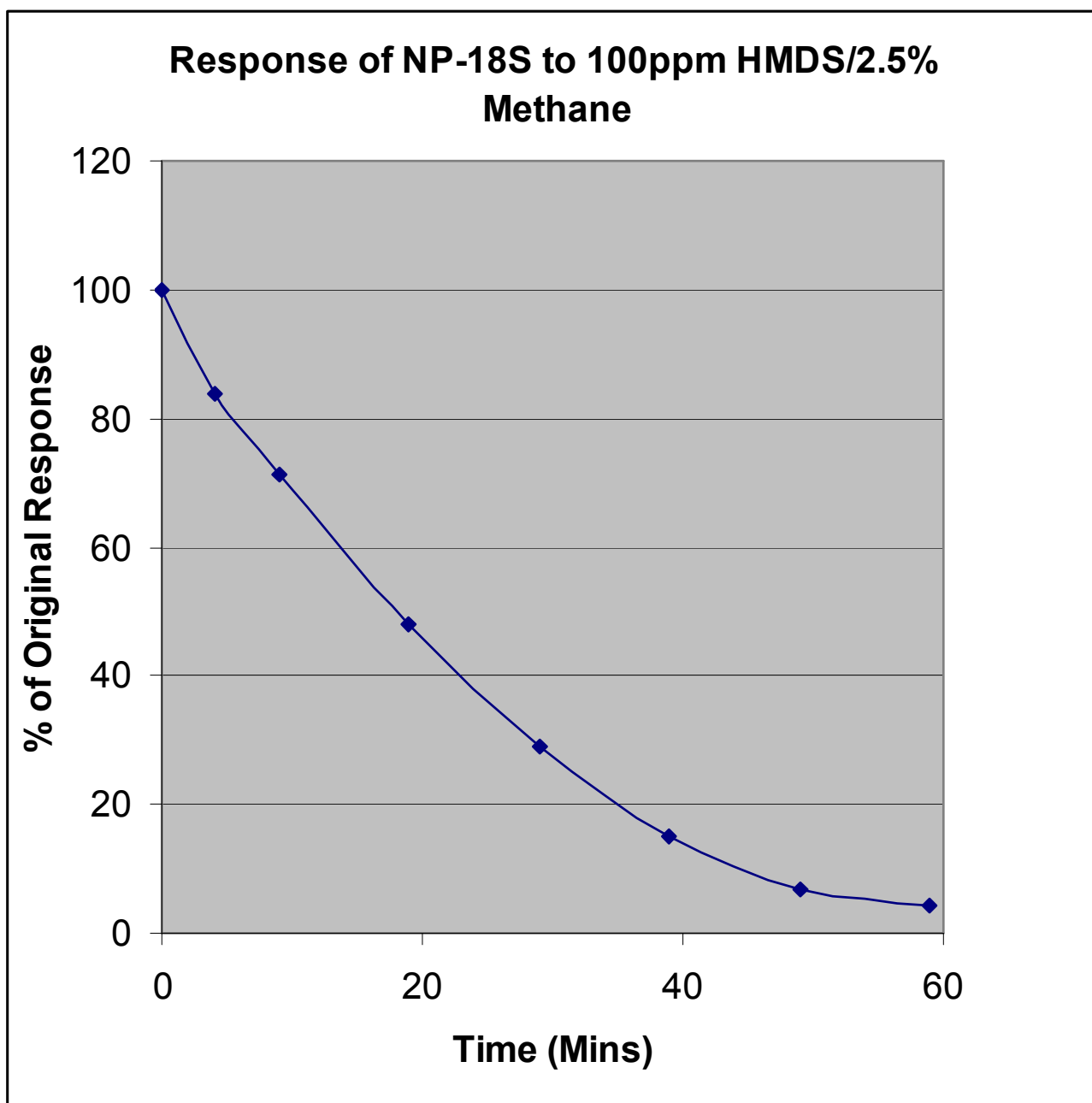

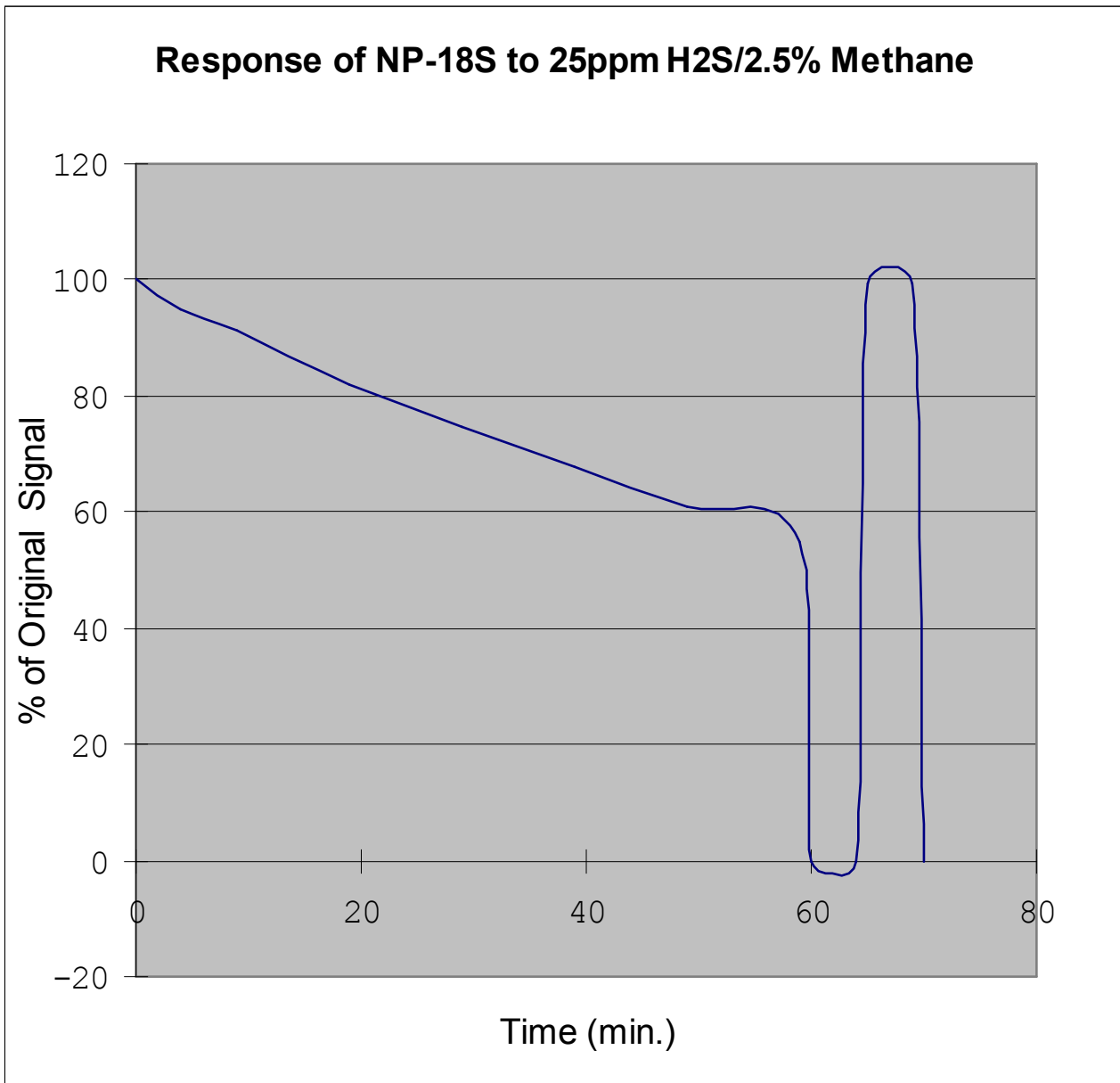

These test results illustrate the effect of H₂S exposure on the sensor and its ability to recover from the effects of H₂S inhibition/poisoning. The sensor was removed from the H₂S gas stream for 5 minutes, The sensor was then exposed to a clean test gas at 2.5% LEL to demonstrate that the inhibiting effect of H₂S does not result in a permanent reduction in signal.



Zero vs Temperature Performance, NP-18S

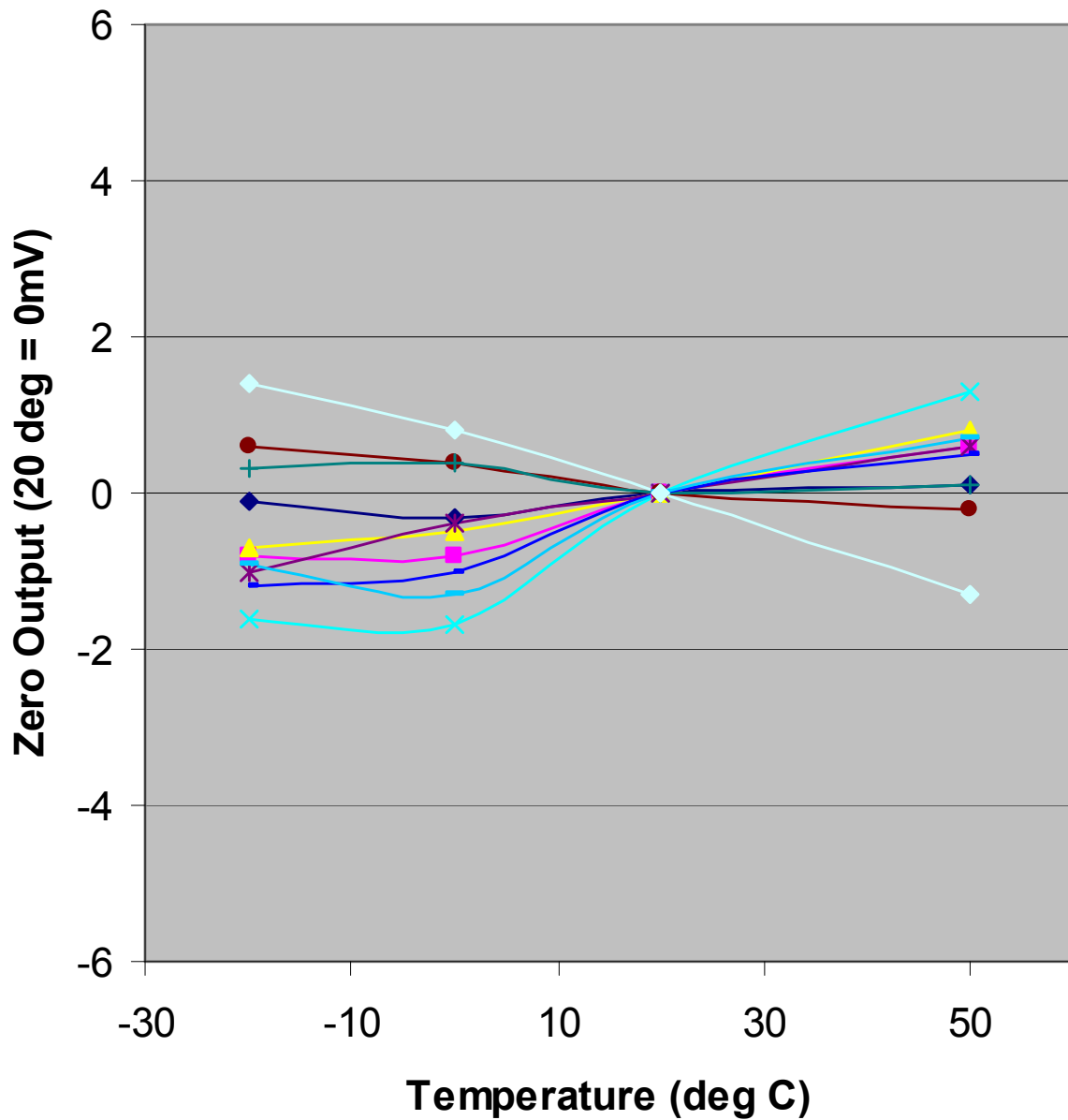



Sensitivity vs Temperature performance, NP-18S

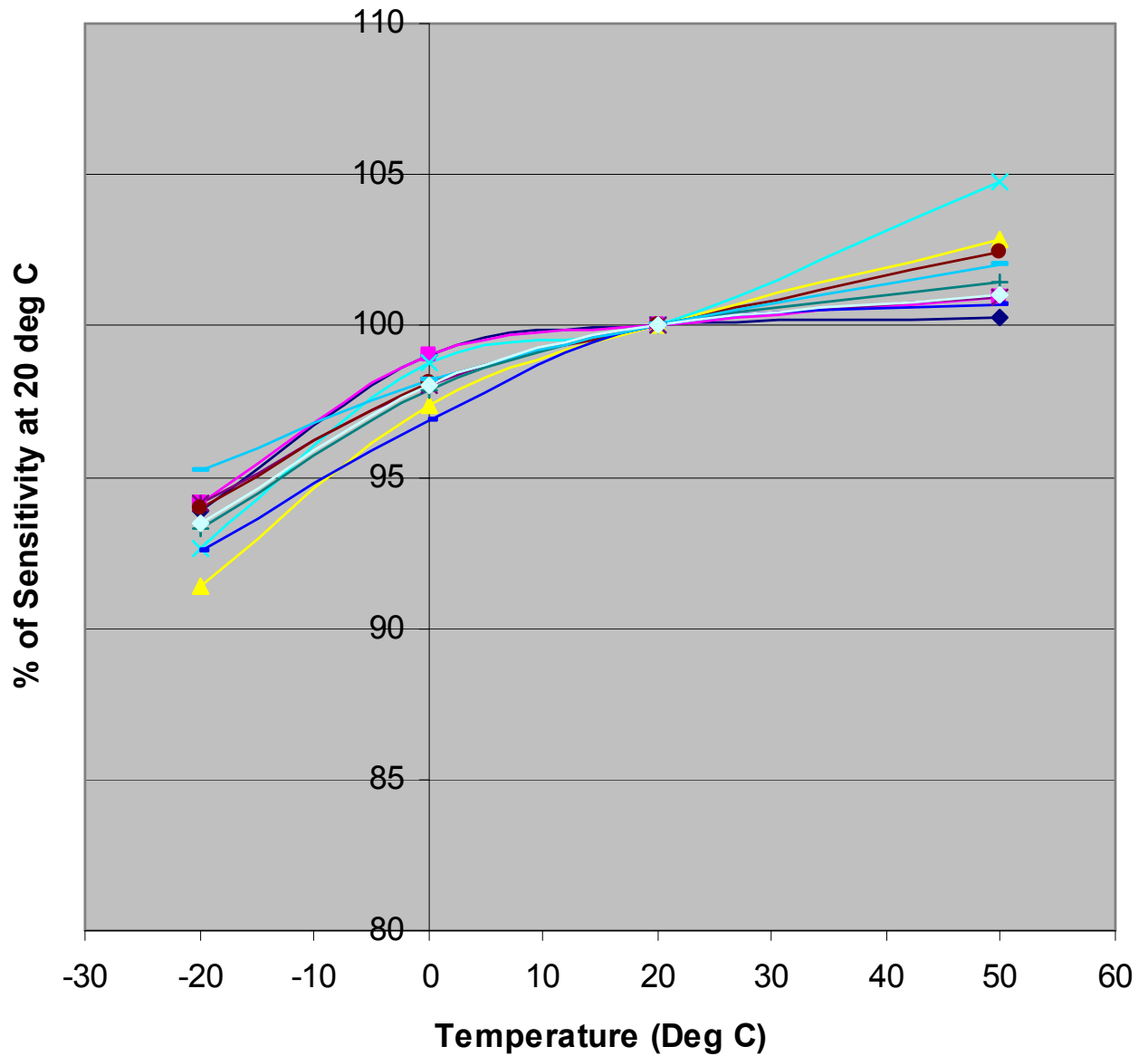



Signal vs Supply Voltage, NP-18S

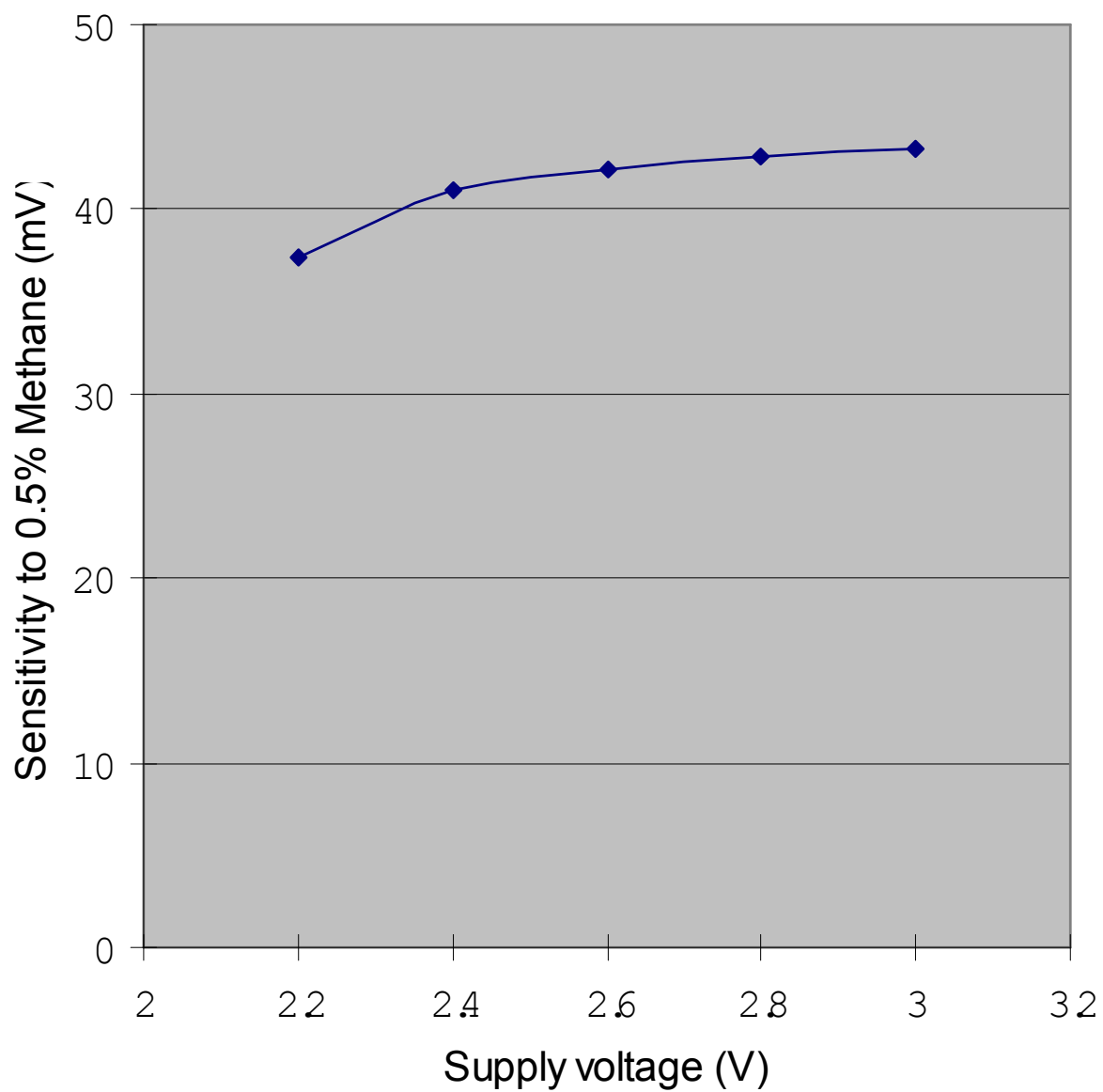



Long Term Zero Stability, NP-18S (1% LEL \equiv 3.75mV)

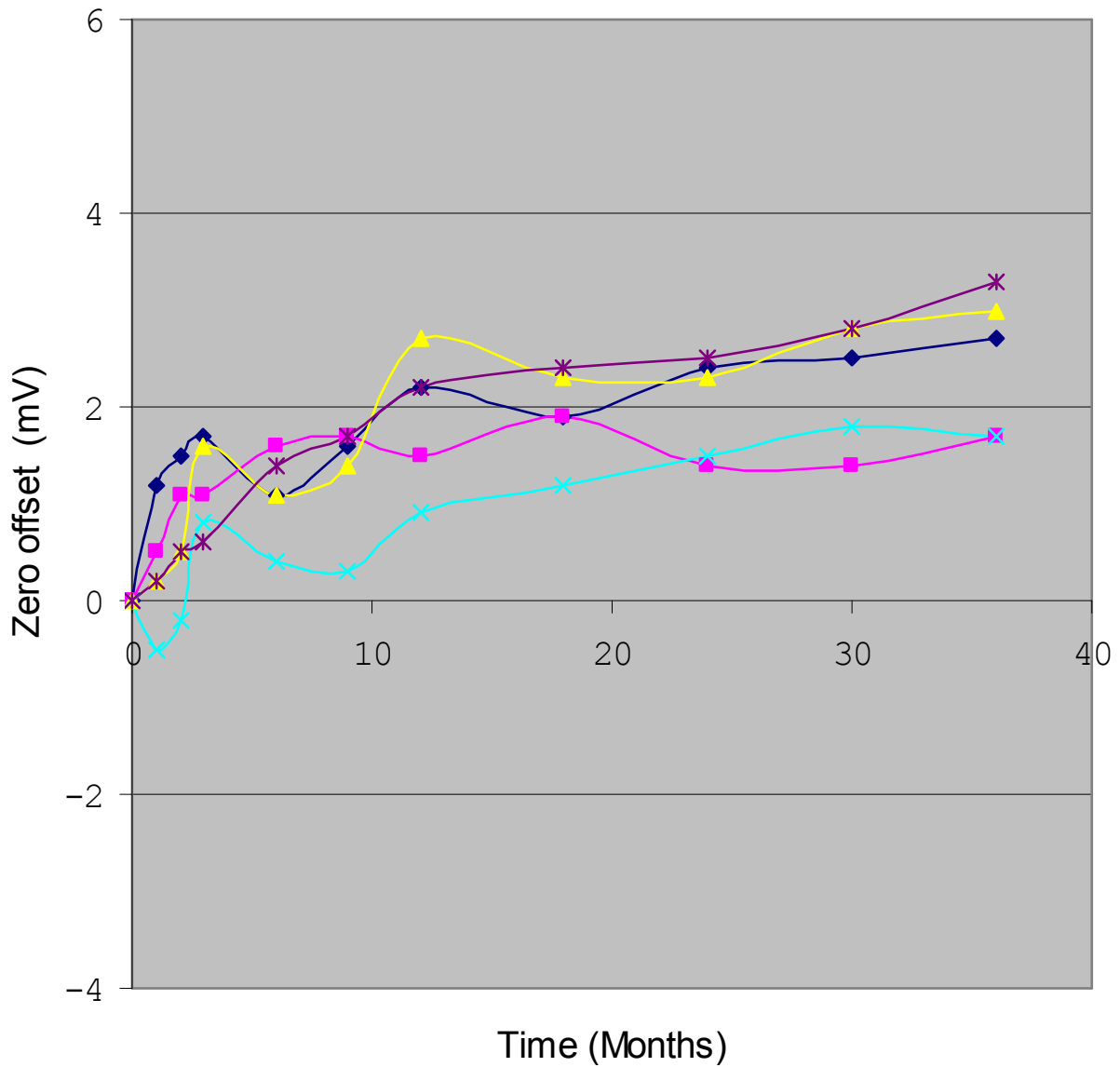



Long Term Signal Stability, NP-18S

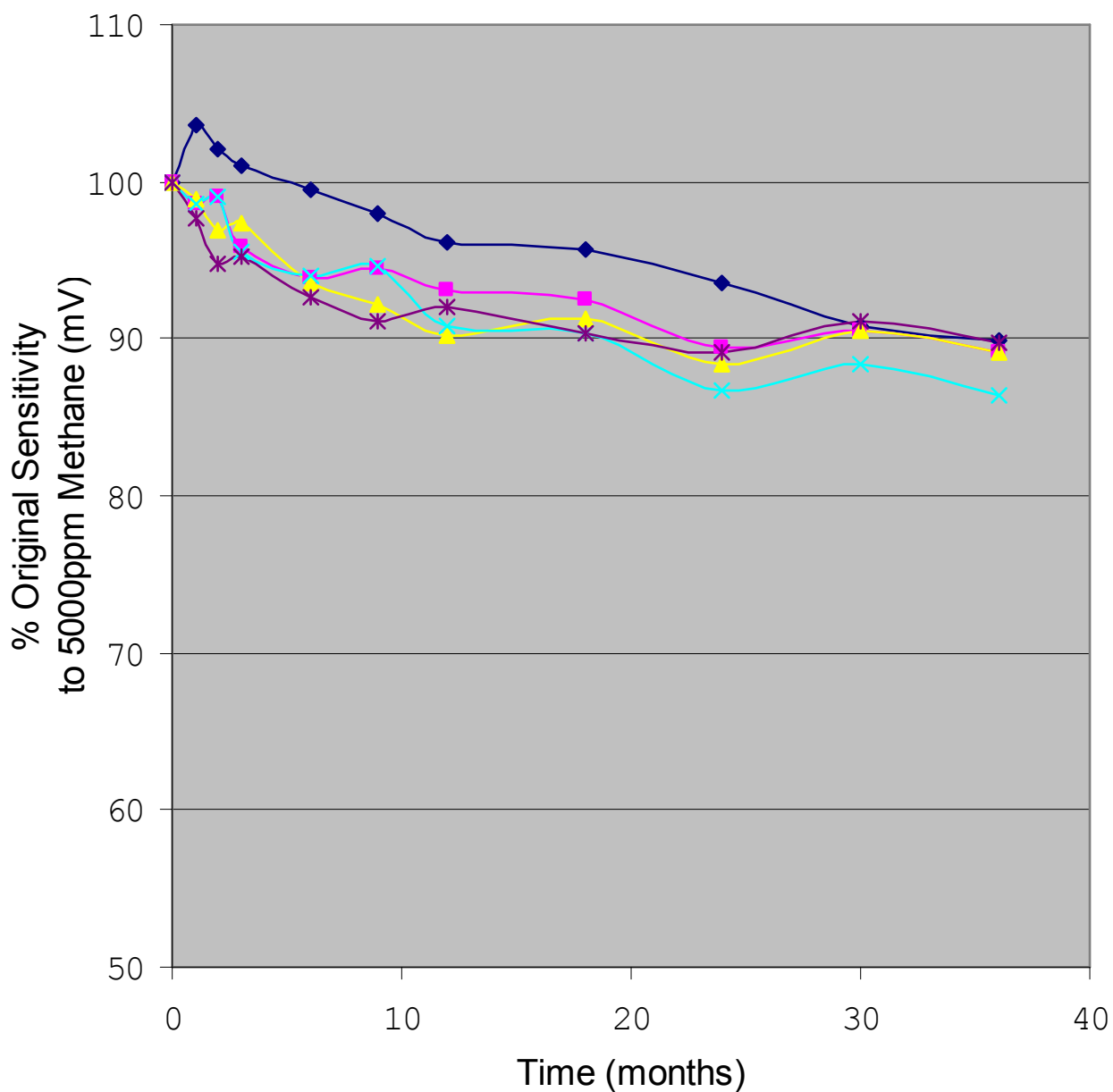



Sensitivity distribution, NP-18S (sample = 300 units)

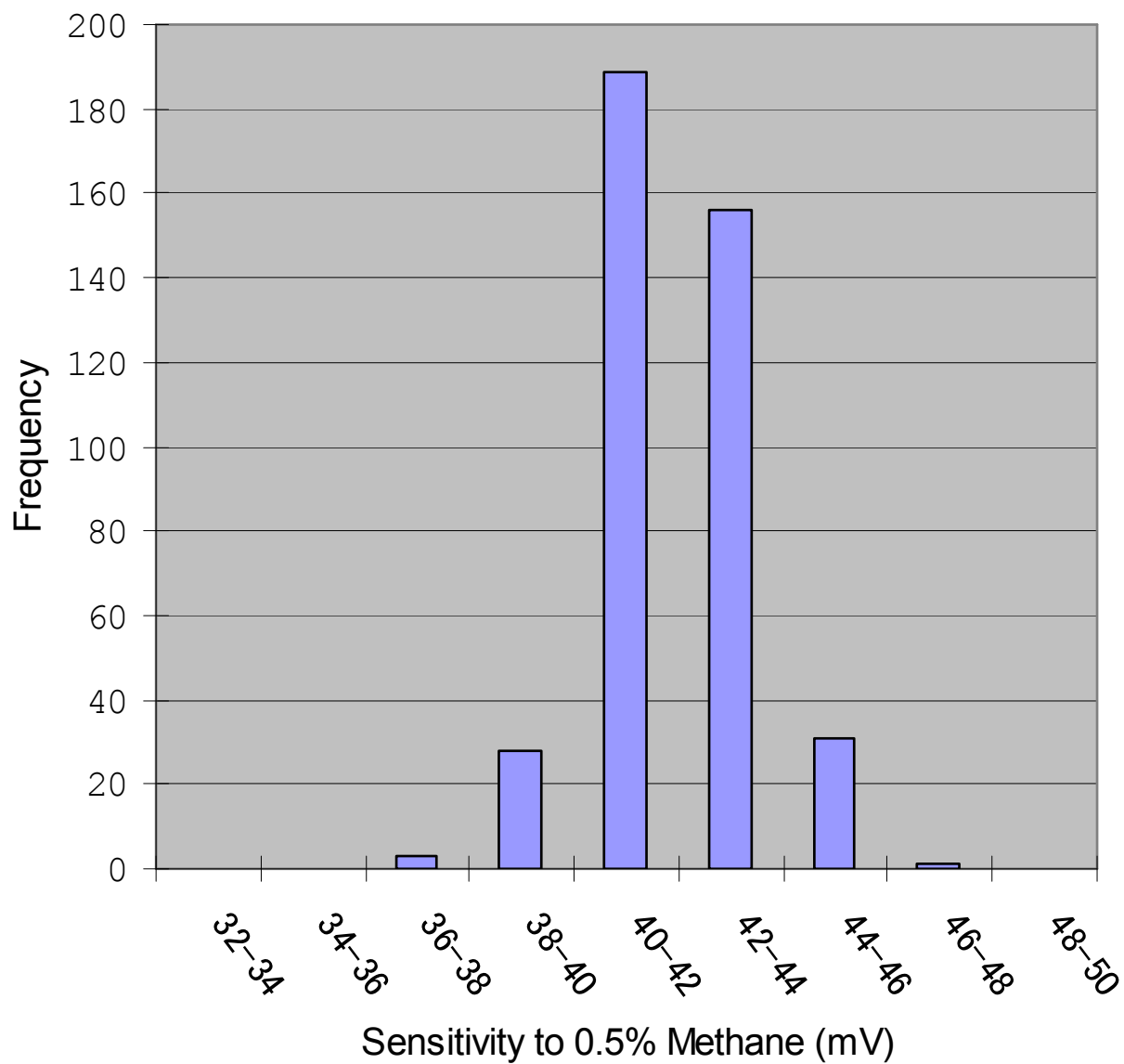

Zero offset distribution, NP-18S

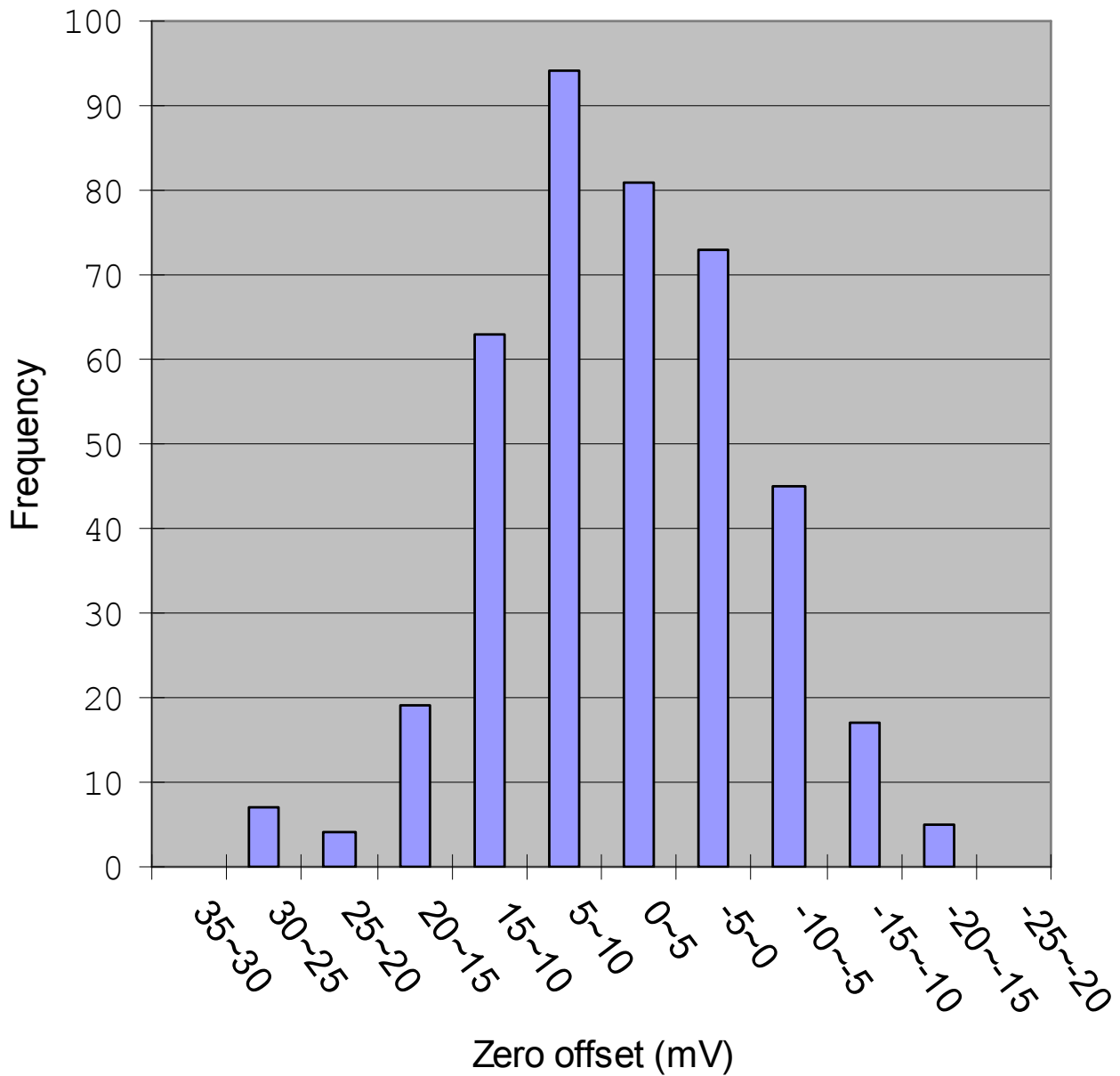



Linearity of NP-18S

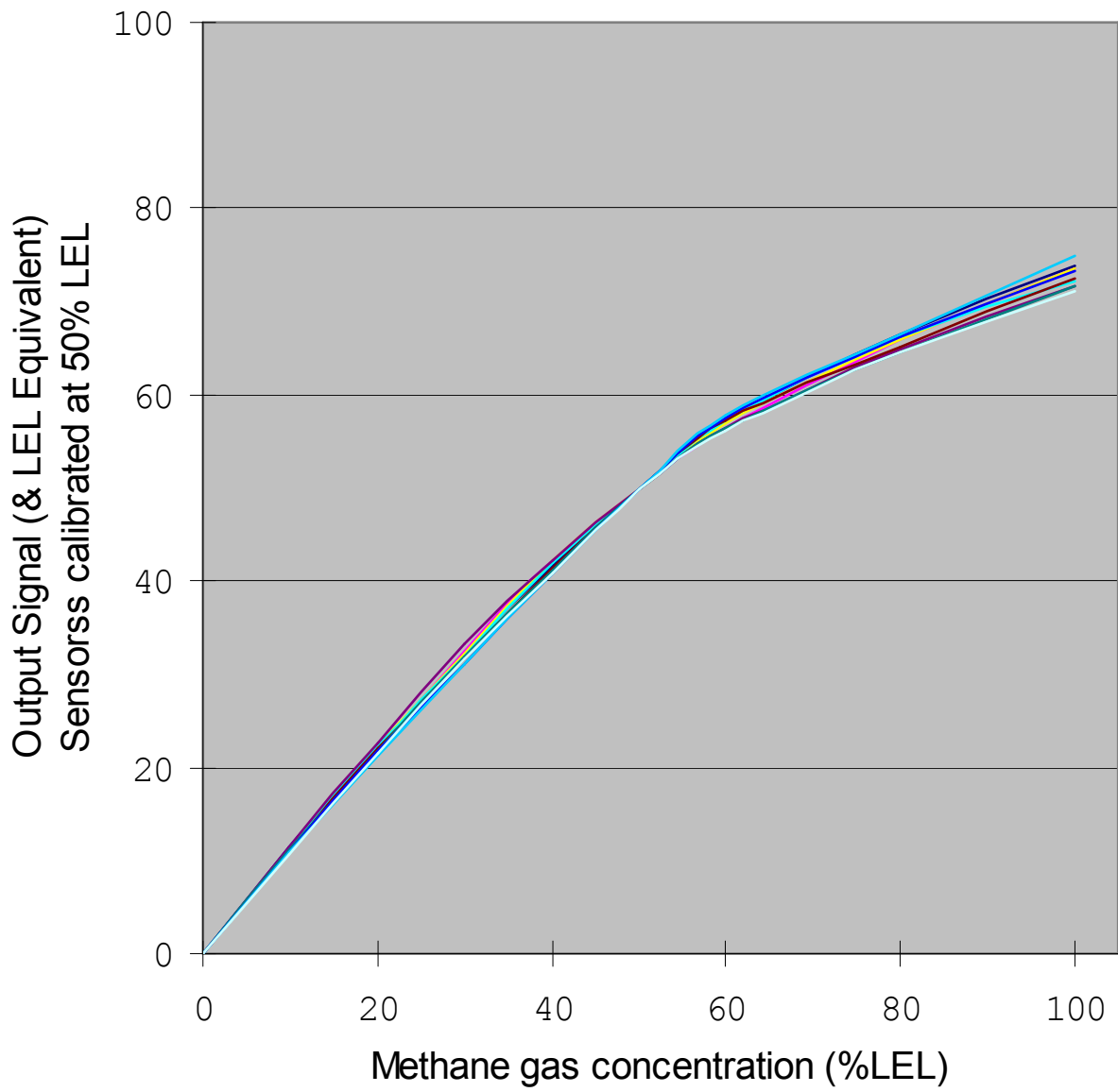



Linearity of NP-18S Average values

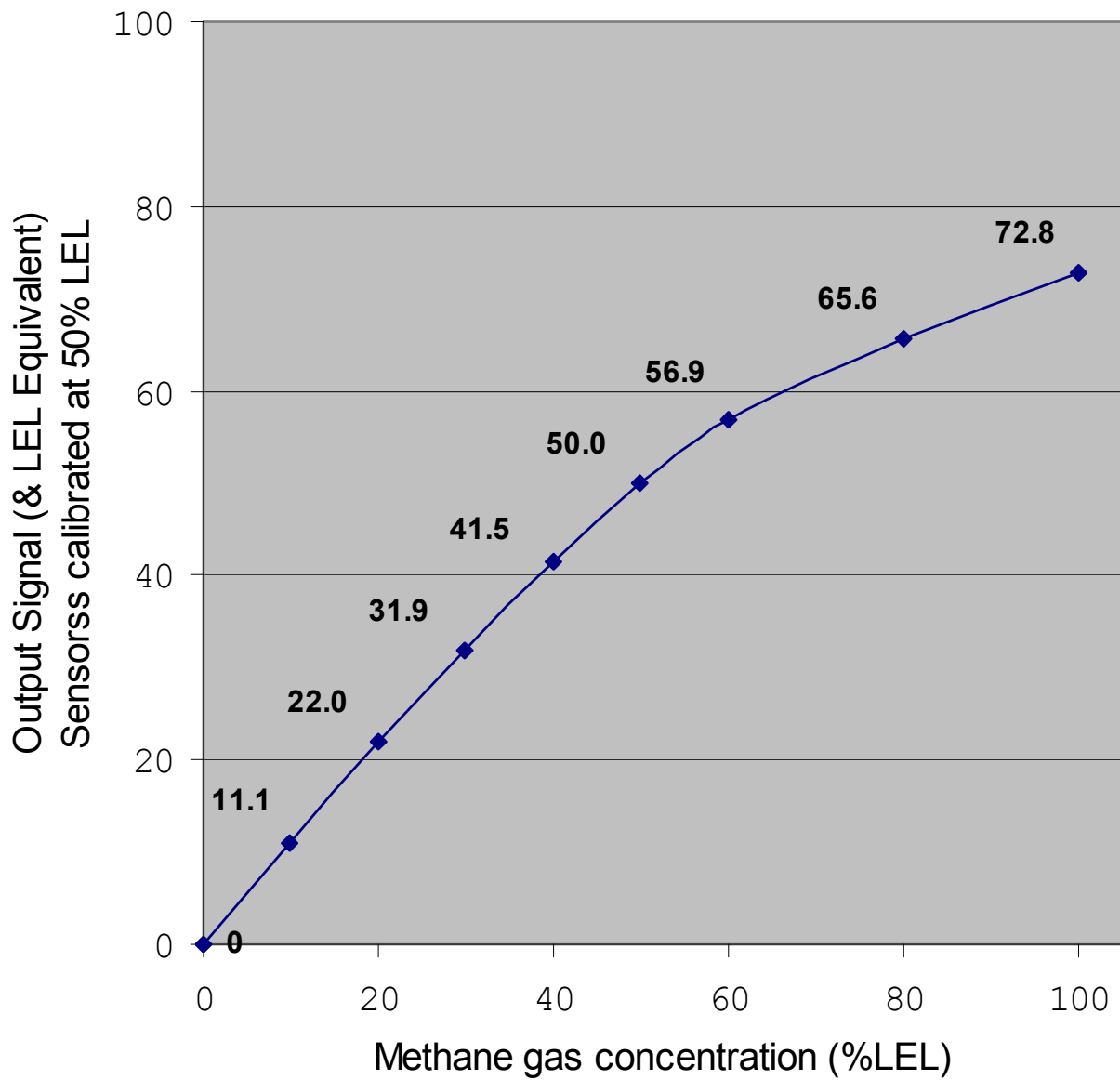



Selected Relative Response Data, NP-18S

Gas/Vapour	LEL (CENELEC Standards)	Relative Response (with respect to Methane)	Gain Adjustment
Acetone	2.6%	0.60	1.66
Ammonia	15%	1.35	0.74
Ethanol	3.3%	0.70	1.43
Ethyl Acetate	2.2%	0.60	1.66
Ethylene	2.7%	0.90	1.11
Hydrogen	4.0%	1.10	0.91
n-Octane	0.95%	0.55	1.82
Iso-Propyl Alcohol (IPA)	2.2%	0.60	1.66
Methane	5%	1.00	1
Methanol	6.7%	1.00	1.00
Methyl Ethyl Ketone (MEK)	1.9%	0.50	2.00
n-Butane	1.8%	0.70	1.43
n-Heptane	1.05%	0.60	1.66
n-Hexane	1.02%	0.70	1.43
n-Pentane	1.4%	0.70	1.43
Propane	2.1%	0.75	1.33
Toluene	1.2%	0.60	1.66
Benzene	1.3%	0.35	2.86
Carbon Monoxide	12.5%	1.10	0.91
Unleaded Petrol (Gasoline)	1.2%	0.60	1.66

Nemoto advises that it is always safest to Calibrate a gas sensor using the gas for which the sensor is intended to detect. However, if that is not possible, the above relative responses may be used when using a methane based test gas to calibrate an NP-18S sensor.